

ADJUST-A-THRUST INSTALLATION INSTRUCTIONS SEA4 - Sea-Doo 4Tec pumps

- ***Before installing the Adjust-A-Thrust, read and understand the instructions and the tuning sheet.**
- *Remove steering cable, trim/ reverse rods, and bilge hoses from the steering nozzle.
- *Remove the bolts that secure the exit nozzle to the pump, and the exit nozzle and wedge if present.
- *Remove the 3 bolts that secure the stock tailcone. Remove the tailcone and tailcone spacer if present.
- *The stock nozzle may need to be bored, refer to the tuning sheet before boring nozzle.
- *Apply an 1/16" bead of ultra blue RTV sealant or equivalent to the body. See diagram below.
- *Install unit so that the inlet orifice points as close to 6:00 o'clock as possible, fasten with hardware provided.
- *Install the 1/4" washer over the shoulder bolt. Next, install the shuttle stop tube (aluminum), then the spring.
- *Install the shortest shuttle into main body, and secure with shoulder bolt assembly.
- *It takes some force to collapse the spring in order to tighten the shoulder bolt into the main body.
- ***When installing the shoulder bolt, Do not torque to over 7 ft/lbs, or you will break off the bolt!!**
- **When tightening the shoulder bolt with the provided wrench, screw it in until it bottoms, then give the wrench about an 1/8 turn more "tweak." Torque is 7 ft/lbs*
- **Once you have determined which shuttle is your favorite, the bolt may be loctited in using yellow loctite only!*
- *Reinstall the exit nozzle and wedge onto pump.
- *Reinstall the trim / reverse rod, steering cable, and bilge and cooling hoses.

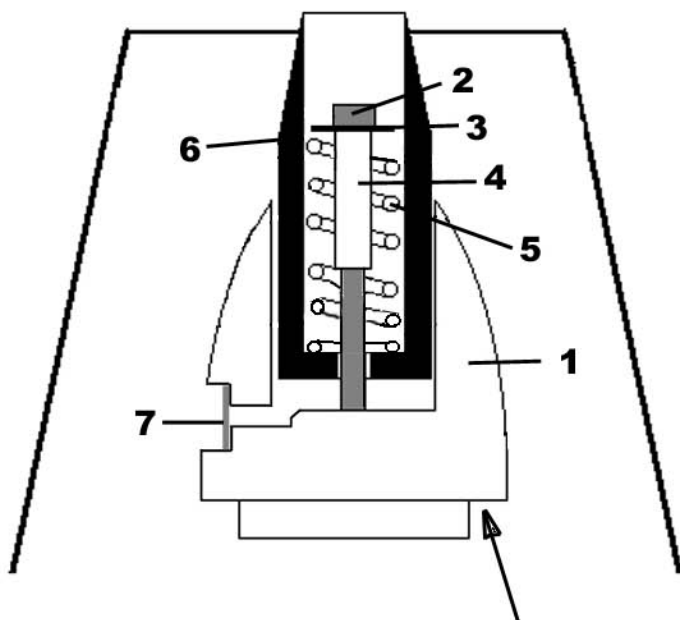

Silicone here

SEA4 parts list

1. MAIN BODY
2. 2.75" X 1/4x20 SS BOLT
2. 2.5" X 1/4x20 SS BOLT (optional, for tuning)
3. 1/4" SS WASHER (1 required, 2 for tuning)
4. SHUTTLE STOP
5. SPRING
6. SHUTTLES (4) 2.0, 2.25, 2.5, 2.75
7. Inlet screen, (optional)
- (3) 6mm SS LOCK WASHERS
- (3) 6 x 1.0 SS CAP SCREWS.

